

DIE SET TABLE CM20M-12/24V



Die #	Crimp.range	D	L
10*	10.0-12.0	10*	55
12*	12.0-14.0	12*	55
14	14.0-16.0	14	55
16	16.0-19.0	16	55
19	19.0-22.0	19	55
22	22.0-26.0	22	55
26	26.0-30.0	26	75
30	30.0-34.0	30	75
34	34.0-39.0	34	90
39	39.0-45.0	39	90
45	45.0-51.0	45	90
51*	51.0-57.0	51*	90
57*	57.0-63.0	57*	90

Benefit:

Compact Design for use in a Van or Truck
 12/24V DC by Battery Power
 Up to 1 1/4" 4SP hydraulic hose

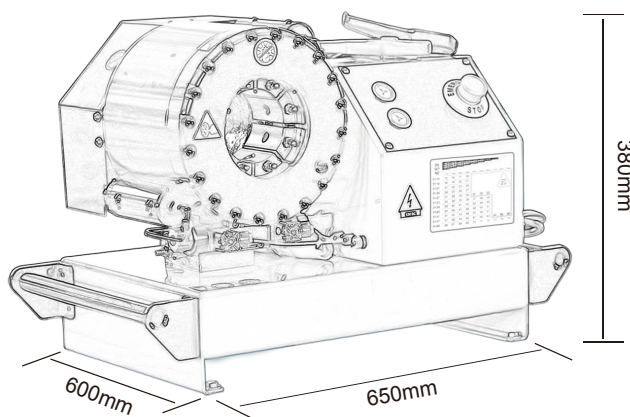

Main Specification	CM20M-12V
	12/24V DC For Mobile Truck
Max Hydraulic Hose	1 1/4"
Crimping Range mm	4-65
Die Type Master Die	P20
Length mm	80
Max Opening mm	+24
Motor KW 12/24	2.2 KW 12V DC
Crimping Force KN	2200
Control	Electrical Control
Foot pedal Die	Optional
Rack	Standard
Quick Change Tool	Standard
Backstop Device	Optional
Noise Level dBA	65
Protection Class	IP56
L * W * H mm	650*600*380
Weight KG	145